

PATON

USER MANUAL
ПОСІБНИК КОРИСТУВАЧА
РУКОВОДСТВО ПОЛЬЗОВАТЕЛЯ

PROMIG-160

PROMIG-200

PROMIG-250

PROMIG-270

PROMIG-350

PROMIG-500

PROMIG-630



PATON INTERNATIONAL





2023-11-29

TABLE OF CONTENTS

1. General	5
------------	---

2. Start-up	9
2.1 Intended use	9
2.2 Space requirements	9
2.3 Power connection	9
2.4 Connecting the mains plug	10
3. Manual metal arc (MMA) welding	10
3.1 Welding process cycle - MMA	11
3.2 "Hot-Start" function	11
3.3 "Arc-Force" function	11
3.4 "Anti-Stick" function	12
3.5 Current-voltage characteristic slope control function	13
3.6 Short-arc welding function	13
3.7 No-load voltage reduction unit function	13
3.8 Pulse current welding function	13
4. Tungsten-arc inert-gas (TIG) welding	14
4.1.1 Welding process cycle - TIG-LIFT	15
4.1.2 TIG-LIFT arc striking function	15
4.1.3 Welding process cycle - TIG-2T	16
4.1.4 TIG-2T torch button function	17
4.1.5 Welding process cycle - TIG-4T	18
4.1.6 TIG-4T torch button function	18
4.2 Pre-current function (pilot arc)	19
4.3 Crater filling current function	19
4.4 Welding current build-up function	19
4.5 Welding current ramp-down function	20
4.6 Pulse current welding function	20
5. Metal-arc inert-gas welding/Metal active gas welding (MIG/MAG)	21
5.1 Welding process cycle - MIG/MAG-2T	23
5.1.1 2T torch button function	23
5.2 Welding process cycle - MIG/MAG-4T	24
5.2.1 4T and alt.4T torch button function	24
5.3 Inductance function	25
5.4 Shielding gas pre-purge function	25
5.5 Shielding gas post-purge function	25
5.6 Beginning of welding voltage/feed speed build-up function	25
5.7 End of welding voltage/feed speed ramp-down function	26
5.8 Motor ON/OFF function	26
6. Selecting and configuring unit functions	26
6.1 Switching to the required function	27
6.2 Switching to the required welding mode	27
6.3 Reset all functions of the welding mode used	28
6.4 Changing the program number in the current welding mode	28
7. General list and sequence of functions	28
8. Generator operation	32
9. Care and maintenance	33
10. Storage	33
11. Transportation	33
12. Scope of supply	33
13. Safety rules	34
14. Warranty obligations	39

Connection to the mains/power distribution panel (at 25°C):
ATTENTION! Please, pay attention to wall wires and other extension cords

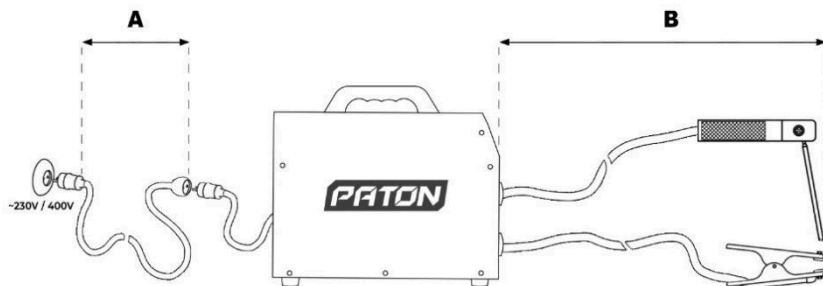

Used MMA electrode	Set current value for MMA and TIG	Wire cross-section diameter for MIG/MAG	[A] Cross section of extension cable, mm ²	[A] Maximum extension cable length, m
1x220V – ProMIG-160, ProMIG-200, ProMIG-250				
Ø2 mm	not more than 80A	not more than Ø0.6 mm	1	75
			1.5	115
			2	155
			2.5	195
			4	310
Ø3 mm	not more than 120A	not more than Ø0.8 mm	6	465
			1.5	75
			2	105
			2.5	130
			4	205
Ø4 mm	not more than 160A	not more than Ø1.0 mm	6	310
			2	75
			2.5	95
Ø5 mm	not more than 200A	not more than Ø1.0 mm	4	155
			6	230
			2.5	75
Ø5 mm Ø6 mm fusible	up to 250 A	not more than Ø 1.2 mm	4	125
			6	185
			2.5	60
			4	100
			6	150

Used MMA electrode	Set current value for MMA and TIG	Wire cross-section diameter for MIG/MAG	[A] Cross section of extension cable, mm ²	[A] Maximum extension cable length, m
3 x 380/400V – ProMIG-270, ProMIG-350, ProMIG-500, ProMIG-630				
Ø3 mm	not more than 120A	not more than Ø 0.8 mm	1.5	135
			2	175
			2.5	220
			4	350
			6	525
Ø4 mm	not more than 160A	not more than Ø 1.0 mm	2	130
			2.5	160
			4	260
Ø5 mm	not more than 220A		6	385
			2.5	115
			4	180
Ø6 mm fusible	not more than 270A	not more than Ø 1.2 mm	6	270
			2.5	85
			4	135
Ø6 mm	not more than 350A	not more than Ø 1.4 mm	6	205
			2.5	65
			4	100
Ø6 mm refractory	not more than 400A	not more than Ø 1.6 mm	6	150
			4	80
			10	195
Ø8 mm fusible	not more than 500A		4	55
			6	85
			10	140
Ø8 mm	up to 630A	not more than Ø2.0 mm	4	40
			6	65
			10	105

1. GENERAL

PATON ProMIG-160/200/250/270-400V/350-400V/500/630 digital semi-automatic inverter units are intended for direct current metal-arc inert-gas welding/metal active gas welding (MIG/MAG), as well as for tungsten-arc inert-gas (TIG) welding and manual metal arc (MMA) welding. The advantages of using a fully digital control method in this unit are that there are no disadvantages inherent in multifunctional systems made based on analogue control systems, which by definition are always configured for a specific mode, and all other modes, as additional ones, have control disadvantages. However, in a fully digital system, the control board has absolutely all the assets of the source, within its full power, and the mode of use does not make any difference. The Professional series is designed for industrial use. The source can be separated from the wire feeder both for ease of operation and for safety, and through additional adjustments, the inverter rectifier can be adjusted to the most optimal settings in various applications. The units provide virtually continuous load duration at full true rated currents of 200, 250, 270, 350, 500 and 630 amperes, respectively, which is enough to work with any electrodes from Ø1.6mm up to the most refractory ones, of Ø8mm (for ProMIG-630) and semi-automatic welding with solid wire with a diameter from Ø0.6mm to Ø2.0mm (for ProMIG-630). The source is initially set to optimal values for most applications, and is quite simple, unless the extensive expertise of the welder enables the use of additional fine-tuned settings. For dangerous operating conditions, a no-load voltage reduction unit is integrated in the MMA mode, with the possibility of switching it on and off. A distinctive feature of PATON semi-automatic units is a very powerful, high-quality and air-tight wire feeder made of metal. Also, the availability of the EURO-type KZ-2 connector, which has become a global standard, allowing the user to subsequently change the torches as seems fit.

In models with the "-15-2" prefix, a **2-roller feeder** is installed, and with the "-15-4" prefix, a top-quality **4-roller feeder** with a drive to all rollers is installed.

All PATON ProMIG models have an integrated under-voltage protection unit.

By increasing the frequency of the applied voltage to the transformer, it became possible to reduce it tenfold. That is why the unit has several times less weight and overall dimensions with the same output parameters, in comparison with the conventional equipment.

The unit saves all current settings at the time of switching off and restores them at the time of switching on.

Main advantages:

1. Wide range of welding parameters adjustment options:
 - a) in the MMA mode - 1 (main) + 7 (optional) + 3 (for pulse mode)
 - b) in the TIG mode - 1 (main) + 7 (optional) + 3 (for pulse mode)
 - c) in the MIG/MAG mode - 2 (main) + 6 (optional)
2. In addition to protection against under-voltage, a stabilization system is installed for operation with **significant long-term** drops in line-to-line voltage from 160V to 260V (for ProMIG-200/250 models) and from 320V to 440V (for ProMIG-270/350/500/630 models).
3. The unit is adapted to a weak power supply. Due to its high efficiency, the source provides **half the power consumption** compared to conventional sources;
4. Adaptive fan speed, i.e., it increases when the unit heats up and slows down when it is cold; this saves the fan life and reduces the amount of dust in the unit;
5. Convenient operation due to the large duty cycle at **rated current**, which allows welding almost **continuously** with electrodes;
6. Increased reliability of the unit in dusty production conditions; microelectronics of the source is housed in a separate compartment;
7. All heating elements of the source are equipped with a **thermal electronic protection system**;
8. All unit's electronics are impregnated with **two layers** of high-quality varnish, which ensures the reliability of the product throughout its entire service life;
9. Improved excitation and arc stability, which virtually eliminates electrode sticking.
10. High mobility due to modular design, as well as small dimensions and weight of the unit without loss of technical qualities, simplifies welding in hard-to-reach places.

PARAMETERS	ProMIG-1 60	ProMIG-2 00	ProMIG-2 50	ProMIG -270	ProMIG -350	ProMIG -500	ProMIG -630
------------	----------------	----------------	----------------	----------------	----------------	----------------	----------------

Rated voltage of mains 50 / 60Hz, V	220 230	220 230	220 230	3x380 3x400	3x380 3x400	3x380 3x400	3x380 3x400
Rated current consumption from the mains phase, A	18 ... 21	23 ... 27	29.5 ... 35	12 ... 14	16 ... 18.5	30 ... 35.5	42 ... 49
Rated welding current, A	160	200	250	270	350	500	630
Maximum operating current, A	215	270	335	350	450	630	800
Load duration (LD)	70%/at 160A 100%/at 134A	70%/at 200A 100%/at 167A	60%/at 250A 100%/at 193A	70%/at 270A 100%/a t 225A	70%/at 350A 100%/a t 290A	70%/at 500A 100%/a t 420A	70%/at 630A 100%/a t 520A
Supply voltage variation limits, V	160 - 260	160 - 260	160 - 260	±15%	±15%	±15%	±15%
Limits of regulation of welding current, A	8 - 160	10 - 200	12 - 250	12 - 270	14 - 350	16 - 500	18 - 630
Limits of regulation of welding voltage, V	12 - 24	12 - 26	12 - 28	12 - 29	12 - 30	12 - 40	12 - 44
Limits of wire feed speed control, m/min	2.0 - 16					2.0 - 20	
MMA electrode diameter, mm	1.6 - 4.0	1.6 - 5.0	1.6 - 6.0	1.6 - 6.0	1.6 - 6.0	1.6 - 8.0	1.6 - 8.0
Welding wire diameter, mm	0.6 - 1.0	0.6 - 1.0	0.6 - 1.2	0.6 - 1.2	0.6 - 1.4	0.6 - 1.6	0.6 - 2.0
Maximum coil weight, kg	15						
Welding pulse modes	MMA: 0.2-500Hz TIG: 0.2-500Hz						
"Hot-Start" in the MMA mode	Adjustable						
"Arc-Force" in MMA mode	Adjustable						
"Anti-Stick" in the MMA mode	Automatic						
Voltage reduction unit, no-load	on / off						
MMA no-load voltage, V	12 / 75						
Arc striking voltage, V	110						
Rated consumption power, kVA	4.1 ... 4.7	5.1 ... 6.1	6.6 ... 7.8	8.0 ... 9.4	10.7 ... 12.3	19.9 ... 23.6	27.8 ... 32.5
Maximum power consumption, kVA	5.9	7.5	9.5	11.4	15.3	29.0	40.1
Efficiency, %	90						
Cooling	Adaptive						
Operating temperature range	-25 ... +45°C						
Overall dimensions, mm (length, width, height)	360 x 260 x 270	360 x 260 x 270	360 x 260 x 270	540 x 360 x 400	540 x 360 x 400	510 x 180 x 385	510 x 235 x 410
Weight without coil and accessories, kg	13,1	13,2	14,0 (16,8)	22,5	22,9	36,7	38,4
Protection rating*	IP33	IP33	IP33	IP33	IP33	IP23	IP23

Recommended length of power welding cables when welding:

Maximum current	[B] Cable length (one way)	Cross-section area	Cable brand
not more than 160A	2 ... 7 m	16 mm ²	KG 1x16
not more than 200A	3 ... 9 m	25 mm ²	KG 1x25
not more than 250A	5 ... 11 m	35 mm ²	KG 1x35
not more than 270A	5 ... 11 m	35 mm ²	KG 1x35
not more than 350A	6 ... 14 m	35 mm ²	KG 1x35
not more than 500A	8 ... 30 m	50 mm ²	KG 1x50
	12 ... 40 m	70 mm ²	KG 1x70
up to 630A	10 ... 30 m	70 mm ²	KG 1x70
	15 ... 40 m	95 mm ²	KG 1x95



1 – Digital display;

- 2 – Buttons for adjusting the selected parameter to decrease and increase (by default: MMA – welding current, TIG – welding current, MIG/ MAG – welding voltage);
- 3 – Source function selection button in the used welding mode;
- 4 – Welding mode selection button:
 - a) manual metal arc welding, MMA;
 - b) tungsten-arc inert-gas welding, TIG;
 - c) metal-arc inert-gas welding/metal active gas welding, MIG/MAG;
- 5 – Unit overheating indicator: normal – OFF, when overheated – flashes;
- 6 – Digital display of the wire feeder;
- 7 – Wire threading button (no gas is supplied);
- 8 – Buttons for decreasing and increasing parameters (by default: wire feed speed);
- 9 – Button for testing shielding gas supply (wire is not fed);
- 10 – Button for selecting functions of the wire feeder;
- 11 – EURO type KZ-2 connector for connecting a semi-automatic torch;
- 12 – Breaker/button for turning on/off the welding current source;
- 13 – Torch button mode indicators (mode 2t/4t/alt.4T);
- A** – Bayonet-type power current socket "+":
 - a) MMA welding – the electrode cable is connected (in more rare cases, when using special electrodes, the ground cable is connected);
 - b) TIG welding – only the ground cable is connected;
 - c) MIG/MAG welding with **solid wire** – the cable is connected to the feeder from inside (by default);
 - d) MIG/MAG welding with **flux-cored wire** – the ground cable is connected;
- B** – Bayonet-type power current socket "-":
 - a) MMA welding – the ground cable is connected (in more rare cases, when using special electrodes, the electrode cable is connected);
 - b) TIG welding – only the TIG torch is connected;
 - c) MIG/MAG welding with **solid wire** – the ground cable is connected;
 - d) MIG/MAG welding with **flux-cored wire** – the cable is connected to the feeder from the inside (it is possible to connect it yourself);
- 14 – Wire coil holder with spring-loaded braking device;
- 15 – Wire feeder and gas heater fuses;
- 16 – Location for connecting the grounding cable;
- 17 – Socket for 36V gas heater;
- 18 – Connector for connecting the control cable from the wire feeder;
- 19 – Power supply cable;
- 20 – Inlet for threading a welding wire;
- 21 – Shielding gas connection.

2. START-UP

Caution! Please, read Section 15 "Safety instructions" before starting-up.

2.1 INTENDED USE

The welding unit is designed exclusively for MMA welding, tungsten-arc inert-gas (TIG) welding, as well as metal-arc inert-gas welding/metal active gas welding (MIG/MAG). Any other use of the unit is inappropriate.

The manufacturer bears no liability for damage caused by using the unit for other purposes. Proper use implies following the instructions in this user manual.

2.2 SPACE REQUIREMENTS

The welding unit can be located and operated outdoors. The internal electrical parts of the unit are protected from direct exposure to moisture, but not from condensation drops.

ATTENTION! After finishing welding in hot weather, or intensive welding in any weather, do not turn off the unit immediately! Wait 5 minutes time to let the electronic components to cool down.

ATTENTION! After operating in the cold season, after switching off and subsequent cooling of the unit, condensation forms inside - do not switch the unit in less than 3 to 4 hours!!! Therefore, do not turn off the unit during the cold season if you plan to turn it on in less than 4 hours.

Place the unit so that cooling air can enter and exit freely through the vents on the front and rear panels. Make sure that no metal dust (e.g. when sanding) is sucked into the unit directly by the cooling fan.

ATTENTION! The unit can be life-threatening after being dropped. Place the unit on a stable solid surface.

2.3 POWER CONNECTION

The standard welding unit is rated for:

1. Mains voltage 220V (-27% + 18%) - for ProMIG-160/200/250 models;
2. Three-phase mains voltage 3x380V or 3x400V (ProMIG-270/350/500/630 models), three wires are dedicated for this. Safety rules when working with welding equipment require grounding of the unit housing. There are two ways to do this: 1) by using the fourth wire in the mains yellow-green cable (international marking standard); 2) by using a bolted terminal on the rear wall of the unit (a stricter grounding standard, used in the CIS countries).

ATTENTION! When the device is connected to a mains voltage higher than 270V (for ProMIG-160/200/250) or 450V (for ProMIG-270/350/500/630), all manufacturer's warranty obligations become invalid!

The manufacturer's warranty obligations also become invalid in case of an erroneous connection of the mains phase to the source ground.

The mains connector, the cross-sections of the mains cables, as well as the mains fuses needs to be selected based on the unit technical data.

2.4 CONNECTING THE MAINS PLUG

ATTENTION! The mains plug needs to match the supply voltage and current consumption of the welding unit (see the technical data). In accordance with the safety

instructions, use a guaranteed ground connection, do not connect to the zero wire of the power supply mains!!!

CAUTION! The mains switch in ProMIG-160/200/250 units is a signal button and cuts off only the power current of the welding unit, but does not completely de-energize the unit's internal electronics. Therefore, for safety reasons, when connecting, do not forget to completely disconnect from the wall socket.

3. MANUAL METAL ARC (MMA) WELDING

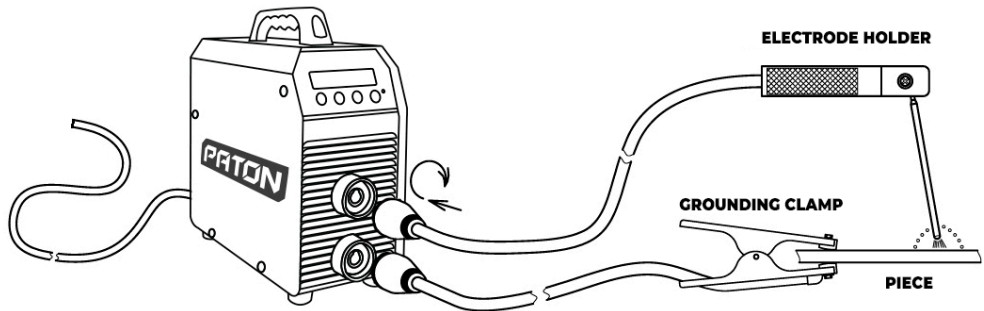

The wire feeder is not required in this welding mode.

Procedure for preparing the unit for operation:

- insert the electrode cable into the socket of the source **A "+"**;
- insert the ground cable into the socket of the source **B "-"**;
- connect the grounding cable to the product;
- connect the mains cable to the power supply;
- put the automatic switch **12** on the rear panel to the ON position;
- use button **4** to set the MMA welding mode (the modes are switched in a circle);
- use buttons **2** to set the current main parameter, this is the welding current;
- if necessary, you can adjust additional functions of the welding process (see paragraph 6.1 for the order of switching).

Caution! In the MMA welding mode, after the mains switch is switched to the "I" position, the MMA is energized. Do not touch conductive or grounded objects such as, e.g., the housing of the welding unit, etc. with the electrode, since the unit will perceive this condition as a signal to start the welding process.

3.1 WELDING PROCESS CYCLE - MMA

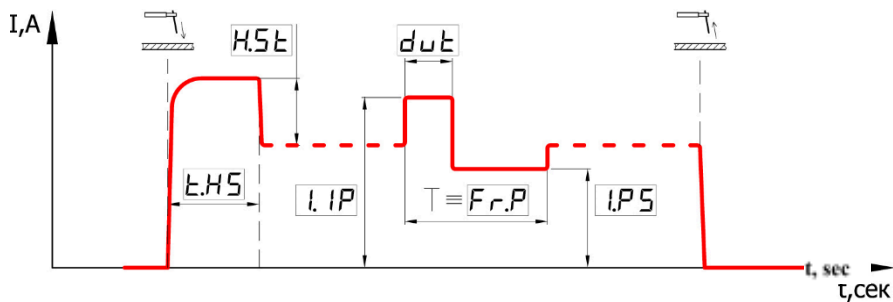

See paragraph 6.1 for the procedure for switching the value of any function

3.2 "HOT-START" FUNCTION

Advantages:

- improved striking even when using poorly ignited electrodes;
- better penetration of the base material during striking, therefore, less lack of penetration;
- prevention of slag inclusions;
- manual setting: allows you to set the function level to the minimum value, which greatly reduces power consumption at the initial moment of striking. This allows the unit to start at mains voltage values close to the minimum possible ones, but reduces the quality of the moment of striking (the unit becomes similar to a transformer source, but it is the only possible way in certain situations). You can also increase the function to the maximum value to further improve the striking timing (when using good mains). However, do not forget that the increased current of this function can burn through the workpiece when welding thin metals, thus, we recommend reducing the "Hot start" function current in this case.

What helps to achieve this: for a short time at the moment of arc striking, the welding current increases by the default level of +40%.

Example: welding with $\varnothing 3$ mm electrode, the set main value of the welding current is 90A.

Result: The hot start current will be $90A + 40\% = 126A$.

In the advanced settings, you can change both the "Hot Start" power [H.St], and the "Hot Start" time [t. HS]. If necessary, do not increase the power and trigger time of the "Hot Start" too much, because it requires a very strong power supply mains at high limit values, and in the absence of good mains, the striking process will fail. See paragraph 6.1 to change the value of any function in the current welding mode

3.3 "ARC-FORCE" FUNCTION

Advantages:

- increasing the stability of short-arc welding;
- improved drop of metal transfer into the weld pool;
- improved arc striking;

- reduces the likelihood of electrode sticking (however, this is not the "Anti-stick" function);
- manual setting: allows you to set the level of the function to the minimum value, which is insignificant, but reduces energy consumption, as well as the concentration of heat input when welding thin metals. This reduces the likelihood of burning through, however, also reduces the stability of short-arc burning (the unit becomes similar to a transformer source). You can also increase the function to the maximum value for even greater short-arc stability, but this requires a better power supply mains and increases the probability of burning the workpiece.

What helps to achieve this: if the arc voltage is reduced below the minimum allowed for stable arcing, the welding current increases by the default level (+40%).

In the advanced settings, you can change both the force of the "Arc-Force" [Ar.F] and the trigger level of the function [u.AF]. Unless required, do not increase the power and level of trigger of the "Arc-Force", because this affects the operation of the "Anti-stick" function at large limit values, especially when welding with thin electrodes (less than Ø3.2 mm).

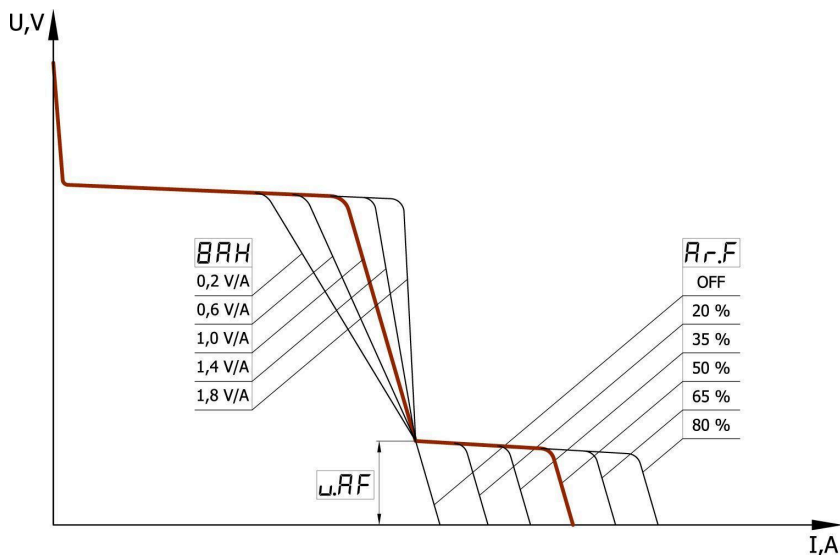

See paragraph 6.1 to change the value of any function in the current welding mode

3.4 "ANTI-STICK" FUNCTION

During the initial arc striking, the electrode may stick (tack to the workpiece). This is prevented by many functions in the unit, but this can still happen, which in turn leads first to incandescence, and then to damage to the electrode. In such a case, the unit's "Anti-stick" function is activated, which is built-in and operates in the MMA mode constantly, which reduces the welding current in 0.6...0.8 seconds after this condition is detected. Also, this makes it easier for the welder to separate (detach) the electrode from the workpiece without the risk of scalding the eyes by accidentally striking the arc. After

the electrode is detached from the workpiece, the welding process can be continued unobstructed.

3.5 CURRENT-VOLTAGE CHARACTERISTIC SLOPE CONTROL FUNCTION

This function is primarily intended for comfortable welding with electrodes with various types of coatings. By default, the current-voltage characteristic slope [CVS] is set to 1.4 V/A, which corresponds to the most common rutile-coated electrodes (ANO-4, MR-3). It is not mandatory for a more comfortable operation with electrodes with the main type of coating (UONI-13/45, LKZ-70), but we recommend setting the slope [CVS] to 1.0 V/A. In turn, the cellulose-coated electrodes (CC-1, VSC-4A) even require setting the slope [CVS] to a value of 0.2...0.6 V/A, and sometimes it is necessary to raise the level of operation of the "Arc-Force" function [u.AF] up to the value of 18V. See paragraph 6.1 to change the value of any function in the current welding mode

3.6 SHORT-ARC WELDING FUNCTION

This function is especially relevant when welding ceiling joints, when you need to make sure that the welding arc does not stretch too much. To do this, you can put the "Short Arc" function [Sh.A] to the ON position. By default, it is in the OFF position. See paragraph 6.1 to change the value of any function in the current welding mode.

3.7 NO-LOAD VOLTAGE REDUCTION UNIT FUNCTION

When performing welding operations in the containers, tanks, and where an enhanced electrical safety system is required, the no-load voltage reduction function can be activated.

When the electrode is detached from the workpiece, after 0.1 seconds, the voltage at the source terminals decreases to a safe level below 12V.

To do this, you need a no-load voltage reduction unit [BSn], which is available in this model, but by default, it is in the OFF position, i.e., off, since it is known that turning on any such function slightly worsens arc striking. See paragraph 6.1 to change the value of any function in the current welding mode.

3.8 PULSE CURRENT WELDING FUNCTION

This function is designed to facilitate the control of the welding process in spatial positions other than the lower one, as well as when welding non-ferrous metals. The effect occurs directly on the mixing of the molten metal of the seam and on the transfer of the drop into the weld pool, and this, in turn, affects the stability of the seam formation and the welding process. In other words, this process replaces the welder's hand movements to some extent, especially in hard-to-reach places. The correct setting determines the shape and quality of the seam formation, which reduces the likelihood of pores and reduces the grain structure, and thus increasing the strength of the welded joint.

To implement this function in the device, you must first enable the current ripple mode [Po.P], switch from the "OFF" state to the "ON" state, and also set four parameters: pulse current [I.IP], pause current [I.PS], pulse frequency [Fr.P] and pulse/pause ratio (or "duty

cycle") [dut]. By default, the ripple frequency [Fr.P] and duty cycle [dut] are at the most common values of 5.0Hz and 50%, respectively. When the "duty cycle" parameter is changed from 50%, an asymmetry is introduced between the current pulse time and the current "pause" time:

default

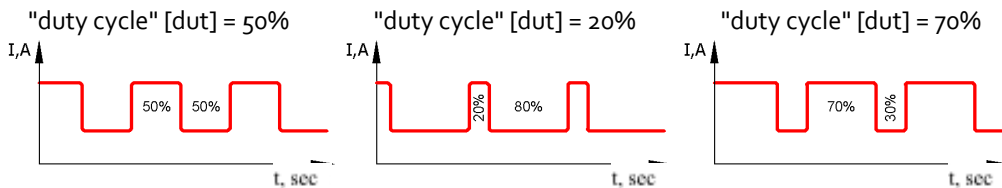

These parameters are set in different situations in different ways, according to the welder's requirements. See paragraph 6.1 to change the value of any function in the current welding mode.

4. TUNGSTEN-ARC INERT-GAS (TIG) WELDING

Caution! As a shielding gas, pure argon "Ar" is most often used, sometimes helium "He", as well as a mixture of them in various proportions.

DO NOT allow the use of flammable gases! Use of other gases is allowed only in agreement with the equipment manufacturer.

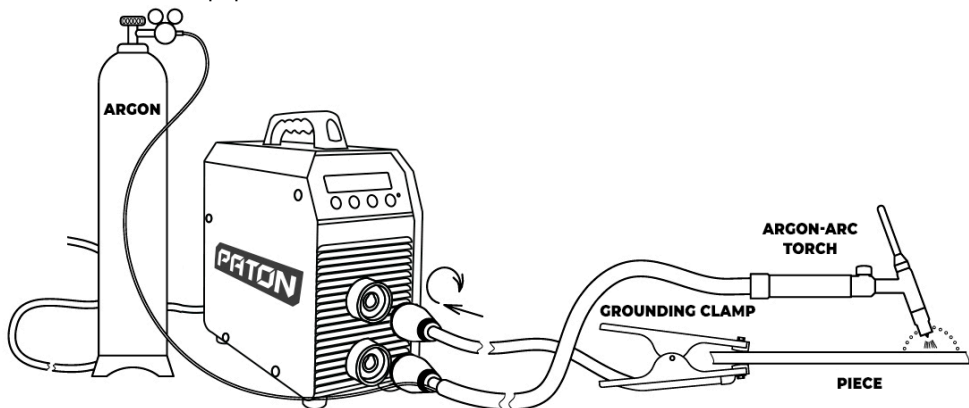

The wire feeder is not required in this welding mode.

Procedure for preparing the unit for operation:

- insert the torch cable into the socket of the source B "-";
- insert the ground cable into the socket of the source A "+";
- connect the grounding cable to the product;
- install the reducing valve on the gas cylinder;
- connect the torch gas hose to the gas cylinder reducing valve;
- open the gas cylinder valve, check for air-tightness;
- connect the mains cable to the power supply;
- put the automatic switch **12** on the rear panel to the ON position;

- use button **4** to set the TIG welding mode (the modes are switched in a circle);
- use buttons **2** to set the current main parameter, this is the welding current;
- if necessary, you can adjust additional functions of the welding process, see paragraph 6.1 for the order of switching.

Caution! The TIG torch must be of valve type, with a $\varnothing 13\text{mm}$ bayonet connector. Choose the maximum torch current according to your operating requirements.

Caution! A common mistake is to sharpen the electrode to a "needle", while the arc can "wag" from side to side. The correct sharpening is a slightly blunted tip, and the fewer are the "needle butts" that can withstand the set current, the better. Keep in mind that at high welding currents, a very sharpened electrode is easily melted due to low heat transfer. Also, the "stripes" from sharpening should be located along the axis of the electrode.

4.1.1 WELDING PROCESS CYCLE – TIG-LIFT

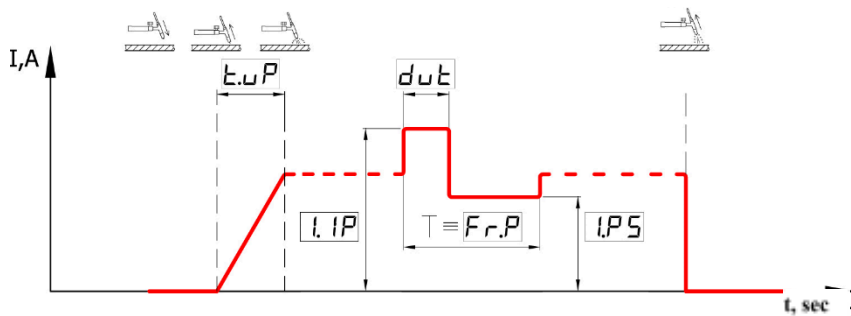

See paragraph 6.1 for the procedure for switching the value of any function

4.1.2 TIG-LIFT ARC STRIKING FUNCTION

This torch button function is set by default in this model of equipment, and is designed for torches with contact arc striking, without using oscillators and other similar units, but unlike the classic method, it completely eliminates the shock current at the time of striking. This function significantly reduces the destruction and ingress of a refractory tungsten electrode into the welding seam, which is a very negative phenomenon.

Caution!!! The workpiece needs to be cleaned at the place of arc striking.

How to use this function is to touch the workpiece with the electrode, while you can hold the electrode in this position indefinitely, and when the user considers that he is ready to start welding (e.g., he lowered the protective mask over his eyes and blew the place well with shielding gas) then it is enough to start SLOWLY lifting the sharpened electrode tip away from the workpiece. The unit will detect this moment and perceive it as a signal to start the welding process, thereby starting to increase the welding current LINEARLY to the set value. The larger the main operating current, the faster you need to raise the electrode, otherwise, it will melt. The time of smooth current build-up [t. uP] to the set value will be reviewed in the following paragraph.

Operation procedure:

- put the automatic switch **12** on the rear panel of the source to the ON position;
- use button **4** to set the TIG welding mode (the modes are switched in a circle);
- set the function of the TIG-LIFT torch button. To do this, hold button 3 until the "Torch button" [But] appears on the indicator; the current position of this function will also be indicated next to it. Using buttons **2**, set "LIFT". If you do not take any action for a long time, the unit will exit this function. You can return in the same way, and if you omitted the required mode of the button, press button 3 again: the functions are switched in a circle;
- use buttons **2** to set the current main parameter, this is the welding current;
- if necessary, you can adjust additional functions of the welding process (see paragraph 6.1 for the order of switching).

4.1.3 WELDING PROCESS CYCLE - TIG-2T

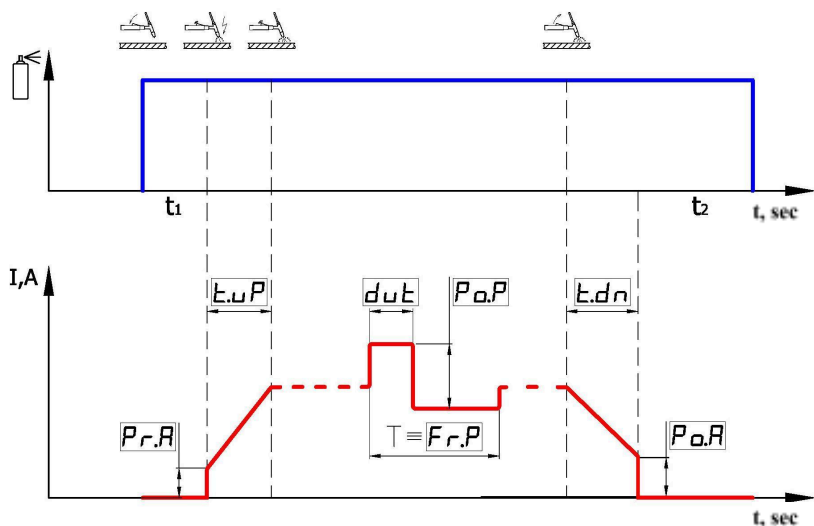

See paragraph 6.1 for the procedure for switching the value of any function

For this mode, you will need to purchase a separate non-contact arc striking unit (oscillator). The procedure for preparing the unit for work with the oscillator is individual and is described in the operation instructions for the oscillator unit. The source control connector is located on the rear panel of the source. Use only pins 1 and 2, DO NOT mix them up with other contacts in – this can lead to unit failure!

Caution! If this connector is not used, cover it with a rubber cap to protect from dirt.

ProMIG-160/200/250/270/350

ProMIG-500/630

digital communications data

данные цифровой связи
(+)motor power supply
(-)motor power supply

(+) питание двигателя
(-) питание двигателя

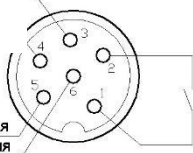

digital communications data 1

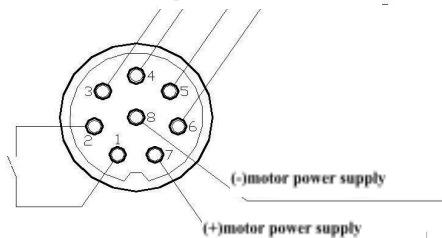

- After assembly:
- turn on the non-contact arc striking unit (oscillator);
- put the automatic switch **12** on the rear panel of the source to the ON position;
- use button **4** to set the TIG welding mode (the modes are switched in a circle);
- set the function of the TIG-2T torch button. To do this, hold button **3** until the "Torch button" [But] appears on the indicator; the current position of this function will also be indicated next to it. Using buttons **2**, set "2T". If you do not take any action for a long time, the unit will exit the mode. You can return in the same way, and if you omitted the required mode of the button, press button 3 again: the functions are switched in a circle;
- use buttons **2** to set the current main parameter, this is the welding current;
- if necessary, you can adjust additional functions of the welding process (see paragraph 6.1 for the order of switching).

Caution! The TIG torch must be a push-button type, with a $\varnothing 13$ mm bayonet connector. Choose the maximum torch current according to your operating requirements.

4.1.4 TIG-2T TORCH BUTTON FUNCTION

This function of the control button is used only if there is an external, independent non-contact arc striking unit (oscillator), with a built-in gas valve. The torch button wire connects directly to the oscillator unit. When the button on the torch is pressed, the control signal is sent to the oscillator unit, which fulfils the function of gas pre-purge **t1** of the welding zone (opens the gas valve) and with a delay gives a signal to turn on the current source; at the same moment, a high-frequency high-voltage pulse is sent to strike the arc. The source triggers all other functions (these will be reviewed in detail in the following paragraphs) according to the cycle of the welding process given above. After releasing the button, the source triggers its functions, and at the end, it automatically turns off. The oscillator unit must trigger the function of gas post-purge **t2** of the welding zone (closes the gas valve with a delay).

ATTENTION! The oscillator unit **MUST** have a circuit to protect the output of the inverter from breakdown by a high-voltage discharge, which it creates at the time of arc striking. Before use, the protection circuit must be activated.

4.1.5 WELDING PROCESS CYCLE - TIG-4T

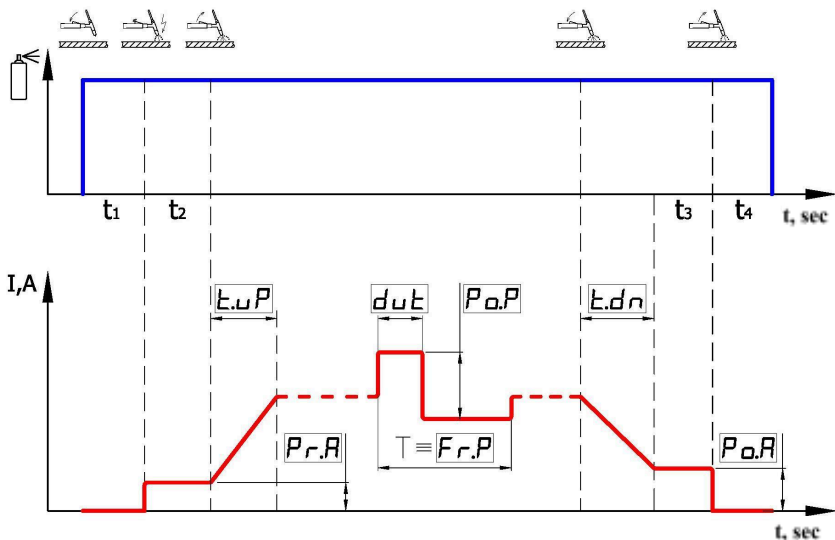

See paragraph 6.1 for the procedure for switching the value of any function

For this mode, you will need to purchase a separate non-contact arc striking unit (oscillator). The procedure for preparing the unit for operation with an external oscillator unit is individual and is described in the operation instructions for the oscillator unit. The source switch control connector is located on the rear panel of the source, the connection diagram is the same as for TIG-2T, see paragraph 4.1.3.

After assembly:

- turn on the non-contact arc striking unit (oscillator);
- put the automatic switch **12** on the rear panel of the source to the ON position;
- use button **4** to set the TIG welding mode (the modes are switched in a circle);
- set the function of the TIG-4T torch button. To do this, hold button **3** until the "Torch button" [But] appears on the indicator; the current position of this function will also be indicated next to it. Using buttons **2**, set "4T". If you do not take any action for a long time, the unit will exit the mode. You can return in the same way, and if you omitted the required mode of the button, press button **3** again: the functions are switched in a circle;
- use buttons **2** to set the current main parameter – the welding current;
- if necessary, you can adjust additional functions of the welding process (see paragraph 6.1 for the order of switching).

Caution! The TIG torch must be a push-button type, with a $\varnothing 13$ mm bayonet connector. Choose the maximum torch current according to your operating requirements.

4.1.6 TIG-4T TORCH BUTTON FUNCTION

This function of the control button is used only if there is an external, independent non-contact arc striking unit (oscillator), with a built-in gas valve. The torch button wire connects directly to the oscillator unit. The procedure for pressing the control button on the torch is similar to the TIG-2T (see paragraph 4.1.4), but with some differences: 1). At

the start of welding, while the button is held down, during the first press, after gas pre-purge **t₁** of the welding zone and high-voltage striking at the source output will be at a constant pre-current **t₂** (pilot arc); only after the button is released, the process of current build-up will begin and the source will reach the operating current, i.e., the button does not need to be held when the operating current is fed; the hand will strain less during a long welding process. 2). At the end of welding (after the second press of the control button on the torch), the current begins to drop to the level of the crater filling current, and while the button is pressed **t₃**, the current is at this level. After the second release of the button, the source is turned off and the oscillator unit triggers its function of gas post-purge **t₄** of the welding zone (the gas valve is turned off with a delay).

ATTENTION! The oscillator unit MUST have a circuit to protect the output of the inverter from breakdown by a high-voltage discharge, which it creates at the time of arc striking. Before use, the protection circuit must be activated.

4.2 PRE-CURRENT FUNCTION (PILOT ARC)

This function is required for the convenience of using the torch at the time of arc striking. It allows you to start the welding process with low current values, the value of which only maintains the process, but does not introduce significant heat input and does not burn the workpiece through. It is possible to preheat the weld spot when using the TIG-4T button mode. By default, the pre-current [Pr.A] is set at 20A. See paragraph 6.1 to change the value of any function in the current welding mode.

4.3 CRATER FILLING CURRENT FUNCTION

This function is necessary to indicate the level to which the current drops at the end of the welding process. It is necessary for crater filling if the TIG-4T button mode is used (with the second press of the torch button). By default, the crater filling current is set at 20A. See paragraph 6.1 to change the value of any function in the current welding mode.

4.4 WELDING CURRENT BUILD-UP FUNCTION

This function, in addition to saving the life of the electrode and, to some extent, the torch itself, is also necessary for the convenience of using the torch. This eliminates the formation of the initial splashing of the weld pool, as well as for the set time of current build-up [t.uP], in the case of the TIG-2T button mode, you can accurately direct the torch to the desired welding location, since the arc striking location in particularly critical workpieces is not always located at the welding location. This function can also be used to preheat the welding location. By default, it is set to OFF – disabled. See paragraph 6.1 to change the value of any function in the current welding mode.

4.5 WELDING CURRENT RAMP-DOWN FUNCTION

This function is necessary to improve the process of filling the crater formed under the pressure of the main working current of the welding arc, and such a crater is the nucleus of weld defects, which is an extremely negative phenomenon. Therefore, for the

set time of the current ramp-down [t.dn], it is possible to weld the formed cavity. By default, it is set to OFF – disabled. See paragraph 6.1 to change the value of any function in the current welding mode

4.6 PULSE CURRENT WELDING FUNCTION

This function is designed to facilitate the control of the welding process in spatial positions other than the lower one, as well as when welding non-ferrous metals. The effect occurs directly on the mixing of the molten metal of the seam, and this, in turn, on the stability of the seam formation. To some extent, it replaces the movement of the welder's hand during welding, especially in hard-to-reach places. There is also partially a forced effect on the transfer of a drop from the filler wire to the weld pool. The correct setting determines the shape and quality of the seam formation, which reduces the likelihood of pores and reduces the grain structure, and thus increasing the strength of the welded joint. To implement this function in the device, you must first enable the current ripple mode [Po.P], switch from the "OFF" state to the "ON" state, and also set four parameters: pulse current [I.i.P], pause current [I.PS], pulse frequency [Fr.P] and pulse/pause ratio (or "duty cycle") [dut]. By default, the ripple frequency [Fr.P] and duty cycle [dut] are at the most common values of 10.0Hz and 50%, respectively. When the "duty cycle" parameter is changed from 50%, an asymmetry is introduced between the current pulse time and the current "pause" time:

default

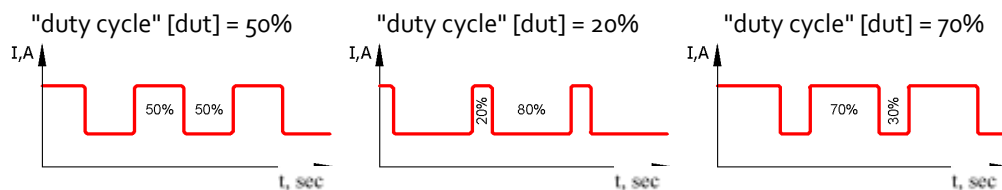

These parameters are set in different situations in different ways, according to the welder's requirements. See paragraph 6.1 to change the value of any function in the current welding mode.

5. METAL-ARC INERT-GAS WELDING/METAL ACTIVE GAS WELDING (MIG/MAG)

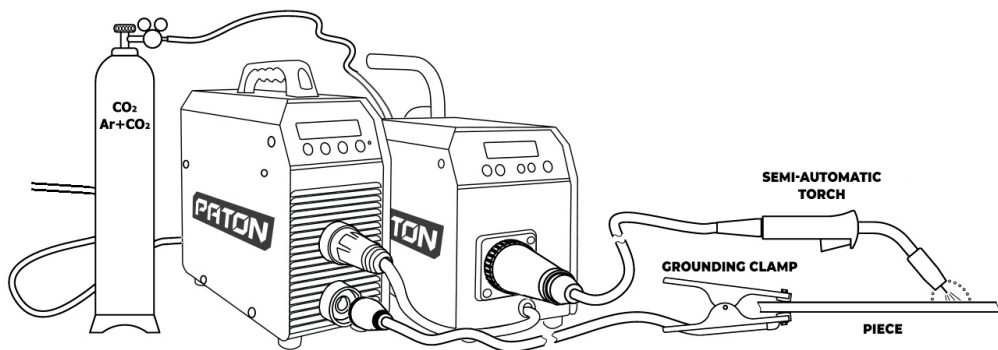

Caution! When welding ferrous metals, in the simplest case, carbon dioxide "CO₂" is used as a shielding gas, and when welding aluminium – only inert gases such as argon "Ar", sometimes helium "He", are suitable. Alternatively, for stainless and high-alloy steels, mixtures in various proportions "80% Ar+20% CO₂" are often used. Use of other gases is allowed only in agreement with the equipment manufacturer.

Caution! Since the unit has a standard EURO type KZ-2 connector for the torch, later you can purchase any torch that seems fit.

The procedure for preparing the unit for welding with **solid wire**:

- install the source on the base of the wire feeder; for better rigidity, tie the source and the base with a belt (through the slit-shaped holes on the sides of the source). Belt is included;
- connect the control cable from the wire feeder to connector 18 on the back of the source;
- insert the ground cable into the socket of the source **B** "-";
- connect the grounding cable to the product;
- connect the power current plug of the wire feeder to the socket of the source **A** "+";
- connect and screw TIG welding torch all the way to socket **11** on the wire feeder;
- install the reducing valve on a gas cylinder with shielding gas "CO₂" or "Ar+CO₂";
- connect the gas hose to the gas cylinder reducing valve and fitting **21** on the rear panel of the wire feeder;
- open the gas cylinder valve, check for air-tightness;
- connect the power supply mains cable to the power supply;
- put the automatic switch **12** on the rear panel of the source to the ON position;
- use button **4** to set the MIG/MAG welding mode (the modes are switched in a circle);
- use buttons **2** to set the required welding voltage;
- install a spool of wire with the required diameter;
- lift up the pressure roller rocker;
- lead the free end of the wire through the inlet channel **20** to the TIG torch;
- lower and clamp the welding wire between the rollers, the pressing force of the rollers is specified on the plastic handle. If you are new to the procedure, then initially set it to the middle position (for an approximate value of 3);
- use buttons **8** to set the required wire feed speed;

- using button **7**, pull the wire through the entire channel and adjust the final pressing force of the rollers, according to the recommendations for MIG/MAG welding. Meanwhile, pay special attention to the clamping force of the coil brake: the coil must be **MINIMALLY CLAMPED AS REQUIRED** and rotate easily, but there should be no spontaneous unwinding. **CAUTION!** If the coil brake mechanism is not assembled correctly, it may "self-tighten" when the coil rotates, which, after a short time, will lead to a complete blocking of the wire with disruption of the welding process. Please double-check before the first wire threading;
- if necessary, you can adjust the additional functions of the welding process at the source and the wire feeder (see paragraph 6.1 for the order of switching).

Do not forget about the supply of shielding gas! To check its availability in the torch channel, there is button **9**: when pressed, the wire is not fed. If you are a beginner and have no experience in setting the optimal pressure for welding a particular product, then at the first time the gas pressure can be set higher than the optimal value of ~0.2 MPa. This will have little effect on the process, only the shielding gas consumption will increase. But in the future, to save money, follow the general recommendations for semi-automatic welding operations. Also start with the average value of the wire feed speed (~ 4 ... 6 m/min) and the average voltage at the source (~ 19V) for any diameter of the installed wire (Ø0.6 ... 1.2mm), it may not be optimal, but the unit should already weld. To achieve the best result, you need to adjust the voltage at the source with buttons **2** and the wire feed speed with buttons **8** on the feed unit according to the general recommendations for carrying out the welding process with semi-automatic units. Remember, these parameters are different for each specific case.

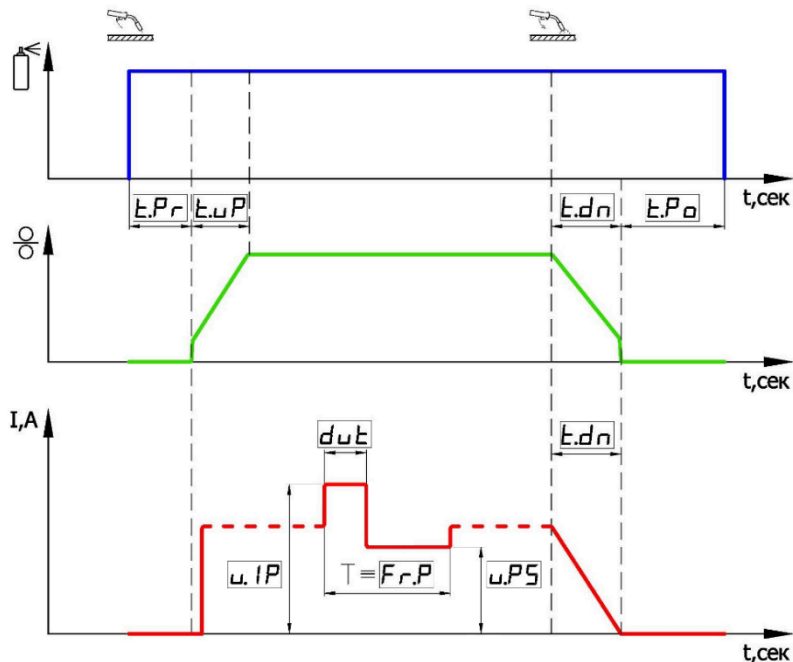

See paragraph 6.1 for the procedure for switching the value of any function

5.1.1 2T TORCH BUTTON FUNCTION

It is used for welding short and medium length welds. The function is as follows: when the button on the torch is pressed, the control signal is given to the control unit, the gas pre-purge function of the welding zone is triggered for the time $[t.Pr]$ (gas valve opens), then a signal is given to turn on the source and the wire feed motor. From this moment, the welding process begins, at the same time the function of smooth reaching the welding mode for the time $[t.uP]$ is triggered, as well as additional functions (e.g., pulse mode) can be triggered, all this according to the cycle of the welding process shown in the sequence diagram in paragraph 5.1. After releasing the button, the function of the ramp-down of the current and the wire feed speed for the time $[t.dn]$ is triggered, and the source is turned off. Next, the function of gas post-purge of the welding zone for the time $[t.Po]$ is triggered (the gas valve closes with a delay).

5.2 WELDING PROCESS CYCLE - MIG/MAG - 4T

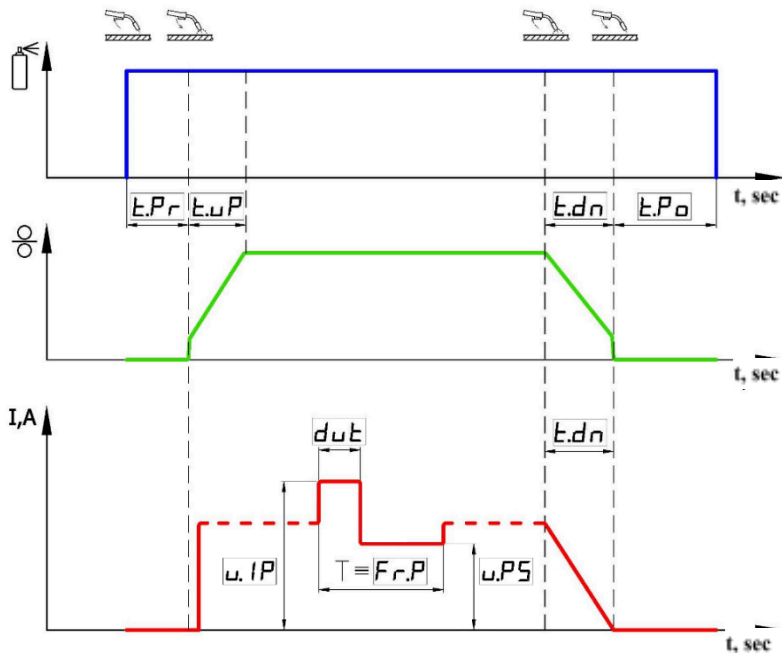

See paragraph 6.1 for the procedure for switching the value of any function

5.2.1 4T AND alt.4T TORCH BUTTON FUNCTION

- the global standard of the button mode is 4T
- alternative button mode is alt.4T

It is used when welding long welds. The function is as follows: when the button on the torch is **pressed for the first time**, the control signal is given to the control unit, the gas pre-purge function of the welding zone is triggered (gas valve opens); after the **first release of the button**, a signal is given to turn on the source and the wire feed motor. From this moment, the welding process begins, at the same time the function of smooth reaching the welding mode for the time [t.uP] is triggered, as well as additional functions (e.g., pulse mode) can be triggered, all this according to the cycle of the welding process shown in the sequence diagram in paragraph 5.2. After **the second press** of the torch button, the function of the voltage and wire feed speed ramp-down for the time [t.dn] is triggered, and the source is turned off.

After **the second release** of the button, the function of gas post-purge of the welding zone for the time [t.Po] is triggered (the gas valve closes with a delay).

In the alternative mode of the Alt 4T button, it skips the second cycle (the first release of the button), and in this way it differs from the global standard 4T. Let us explain: in this case, the system does not wait for **the first release** of the torch button, but immediately after the function of gas pre-purge of the welding zone for the time [t.Pr] starts the process of arc striking - this is the same as in the 2T button mode. In this case,

after **the first release**, the welding process continues unchanged. This mode is provided by PATON as a bonus one, use it as desired, since it is more common from the point of view of more frequent use of 2T mode by customers in conventional semi-automatic units, therefore, it is more user-friendly.

5.3 INDUCTANCE FUNCTION

This function is required to change the rate of current build-up when the arc voltage changes. As a result, spatter is reduced, but it also affects the drop transfer process, which at high inductance values leads to a slowdown in the welding process and a strong decrease in the drop transfer frequency. By changing the value of this function, each user can choose the optimal welding process for themselves. In general, the minimum values are used for welding thickness of more than 3 mm, and the maximum values are used for thinner products.

Also, to quickly change the inductance level, it is necessary to press and hold button **4** on the front panel of the machine for more than 1 second. After this, the corresponding parameter will appear on the screen, and you can change the value of this parameter by using buttons **2**.

By default, the inductance is set to OFF, i.e. set to zero stage. See paragraph 6.1 to change the value of any function in the current welding mode.

5.4 SHIELDING GAS PRE-PURGE FUNCTION

This function is necessary to protect the welding zone from the harmful effects of atmospheric air, and consists in pre-purging the welding zone with shielding gas before striking the welding arc. By default, the "pre-purge time" [t.Pr] is set to 0.1 sec; this value can be changed at any time at your discretion. See paragraph 6.1 to change the value of any function in the current welding mode. Use a right wire feeder indicator.

5.5 SHIELDING GAS POST-PURGE FUNCTION

This function consists in the post-purging of the welding zone with a shielding gas after the welding arc is extinguished, since the hot weld pool is afraid of the harmful effects of atmospheric air for some time. By default, the post-purge time [t.Po] is set to 1.5 seconds; this value can be changed at any time at your discretion. See paragraph 6.1 to change the value of any function in the current welding mode. The left source indicator and the right wire feeder indicator can be used.

5.6 BEGINNING OF WELDING VOLTAGE/FEED SPEED BUILD-UP FUNCTION

This function is necessary to smoothly reach the welding mode in the set time [t.uP], which reduces splashing of the weld pool and splatter at the moment of striking, when the wire is still cold. The extended smooth reach time is used for the initial weld pool formation.

CAUTION! The longer the build-up time, the smaller the initial weld, so it is used only for medium and long seams. For this reason, do not increase the time by more than 0.1 seconds when welding with tacks, etc.

By default, the reach time is set to OFF, i.e. disabled. See paragraph 6.1 to change the value of any function in the current welding mode.

CAUTION! When welding with **steel** wire, the build-up time [t.uP] at the source must be either equal to or slightly less than that at the wire feeder. When welding with **aluminium** wire, the build-up time [t.uP] at the source must be longer (+0.2...+ 0.5 sec) than that at the wire feeder.

5.7 END OF WELDING VOLTAGE/FEED SPEED RAMP-DOWN FUNCTION

This function is designed for smooth welding of the crater formed in the weld pool under the influence of electromagnetic blast with an electric arc and subsequently being a source of welding seam defects. The signal to start the function is to release the button on the torch at the end of the welding process, and the movement of the torch must be stopped and a pit (which is essentially a crater) in the welding seam must be welded with a reducing voltage. The smoothness of this process is regulated by the voltage ramp-down time [t.dn] of the source, and the ramp-down time of the wire feed speed [t.dn] of the feed mechanism. These values must match for correct operation. By default, the value is set to 0.1 sec, i.e., in fact, in the OFF state. You can change this value at your own discretion. See point 6.1 for the switching procedure.

CAUTION! When welding with **steel** wire, the reduction time [t.dn] at the source must be either equal to or slightly more than that at the wire feeder. When welding with **aluminium** wire, the reduction time [t.uP] at the source must be less (-0.3...-0.7 sec) than that at the wire feeder.

5.8 MOTOR ON/OFF FUNCTION

This additional function is provided to turn the motor on/off. It may not be available in the menu, since if there is a connection between the control units, the welding unit itself decides to turn on and off the motor in a specific welding mode.

CAUTION! For the correct operation of the semi-automatic unit, this parameter must always be in the ON position.

6. SELECTING AND CONFIGURING THE UNIT FUNCTIONS

If you do not press the buttons on the front panel, the unit displays the value of the main parameter of the current welding mode on the digital indicator on the left:

- 1) in the MMA mode – welding current;
- 2) in the TIG mode – welding current;
- 3) in the MIG/MAG mode – welding voltage.

During the MIG/MAG welding, the left display shows the current value of the current resulting from the following factors: used wire diameter, set voltage value at the source, set wire feed speed on the feeder, gas used, material and the thickness of the workpiece to be welded, etc. The value is shown within 8 seconds after the end of welding, this is necessary for the welder to be able to double-check the current value, without any outside help. In the MIG/MAG mode, the digital indicator on the right side shows the value of the wire feed speed in "m/min".

Button **3** on the front panel of the unit is responsible for selecting the source function in the current welding mode, and button **10** is responsible for selecting the function of the feeder in MIG/MAG mode.

Button **4** on the front panel of the unit is responsible for selecting the welding mode.

Buttons **2** on the front panel of the source are responsible for changing the current value on the digital indicator on the left.

Buttons **8** on the front panel of the feeder are responsible for changing the current value on the digital indicator on the right.

6.1 SWITCHING TO THE REQUIRED FUNCTION

If the unit has a system of protection against unauthorized access to the function menu, then if you press button **3** on the source, no changes are made on the left indicator, i.e., this button is locked. To unlock, hold it down for more than 3.5 seconds. When unlocking, the indicator displays an image of opening locks, indicating the process of unlocking the function menu. After successful unlocking, by pressing button **3**, the current name of the function and its value are displayed on the digital display.

Caution! After releasing button **3** after 2 seconds, the screen will return to the main parameter of the current welding mode. While the display is showing the current function, its value can be changed up or down using buttons **2**. Alternatively, by quickly pressing and releasing button **3**, you can switch to the next function, in a circle.

Caution! If you hold down button **3** for more than 10 seconds, then the countdown will appear on the display 333... 222... 111 ...; release the button before this time expires, so as not to reset all the settings of this mode to the standard factory settings. This will be reviewed in paragraph 6.3.

Similarly, by pressing button **10**, the digital indicator on the right displays the graphic name of the current function of the wire feeder, and immediately after releasing it, the current value of this function is displayed for 2 seconds. You can change the value up or down with buttons **8**.

If the menu is locked, as is the case with the function menu on the source, simply hold this button for more than 3.5 seconds

6.2 SWITCHING TO THE REQUIRED WELDING MODE

Pressing button **4** leads to switching to the next welding mode in a circle, this can be seen on display **1** on the front panel.

6.3 RESET ALL FUNCTIONS OF THE WELDING MODE USED

Situations may occur when the unit's settings have somewhat confused the user. In order to reset their values to the factory default, use the same button **3**, used to enter the function menu. To reset the settings, simply hold down button **3** for more than 10 seconds (ignore the animation of locks). The scoreboard will start counting down 333...222...111 and when "000" is reached, all settings of the current welding mode will be updated to factory settings. Resetting parameters for each welding mode is performed

separately! This is provided for convenience, so as not to accidentally reset individual settings in the other two modes.

Similarly, you can reset the parameters on the wire feeder using button **10**.

6.4 CHANGE THE PROGRAM NUMBER IN THE CURRENT WELDING MODE

In each MMA, TIG and MIG/MAG welding mode, the user can save up to 16 different settings. The current preset (program) number is displayed in the upper right corner of the indicator of the source on the front panel. When the unit is turned on for the first time, the program is always No. 1 for each welding mode. All changes in the setting of the unit in this welding mode and the current program number are saved. To switch to another program number and start setting again from the basic parameters, simply press button **3**, and if the function selection menu is locked, then the indicator displays the current program number, which can be changed up or down using buttons **2**. If the function selection menu is not locked, e.g.: just before that the user changed the additional parameters of the functions described in paragraph 6.1, then it is necessary to lock the function selection menu by holding button **3** for more than 3.5 seconds, just like when unlocking, in this case, the closing locks animation will be displayed on the indicator. When this operation is completed, the menu will be locked, and now you can try again to change the program number using button **3**. In this case, all parameters of the previous program will be saved and you can always return to it at any time.

7. GENERAL LIST AND SEQUENCE OF FUNCTIONS

MMA welding mode

- o) [- 1 -] - main displayed parameter CURRENT = 90A (by default)
 - a) 8 ... 160A (change step 1A) for ProMIG-160
 - b) 10 ... 200A (change step 1A) for ProMIG-200
 - c) 12 ... 250A (change step 1A) for ProMIG-250
 - d) 12 ... 270A (change step 1A) for ProMIG-270
 - e) 14 ... 350A (change step 1A) for ProMIG-350
 - f) 16 ... 500A (change step 1A) for ProMIG-500
 - g) 18 ... 630A (change step 1A) for ProMIG-630
- 1) [H.St] Hot start power = 40% (by default)
 - a) 0[OFF] ... 100% (change step 5%)
- 2) [t.HS] Hot start time = 0.3 sec (by default)
 - a) 0.1 ... 1.0 sec (change step 0.1 sec)
- 3) [Ar.F] Arc Force power = 40% (by default)
 - a) 0[OFF] ... 100% (change step 5%)
- 4) [u.AF] Arc force trigger level = 12V (by default)
 - a) 9 ... 18V (change step 1V)
- 5) [CVS] current-voltage characteristic slope = 1.4 V/A (by default)
 - a) 0.2 ... 1.8 V/A (step change 0.4 V/A)
- 6) [Sh.A] short arc welding = OFF (by default)
 - a) ON – enabled

- b) OFF – disabled
- 7) [BSn] voltage reduction unit = OFF (by default)
 - a) ON – enabled
 - b) OFF – disabled
- 8) [Po.P] current pulsation mode = OFF (by default)
 - a) ON – enabled
 - b) OFF – disabled
- 9) [I.iP] pulse current = 90A (by default)
 - a) 8 ... 160A (change step 1A) for ProMIG-160
 - b) 10 ... 200A (change step 1A) for ProMIG-200
 - c) 12 ... 250A (change step 1A) for ProMIG-250
 - d) 12 ... 270A (change step 1A) for ProMIG-270
 - e) 14 ... 350A (change step 1A) for ProMIG-350
 - f) 16 ... 500A (change step 1A) for ProMIG-500
 - g) 18 ... 630A (change step 1A) for ProMIG-630
- 10) [I.PS] pause current = 90A (by default)
 - a) 8 ... 160A (change step 1A) for ProMIG-160
 - b) 10 ... 200A (change step 1A) for ProMIG-200
 - c) 12 ... 250A (change step 1A) for ProMIG-250
 - d) 12 ... 270A (change step 1A) for ProMIG-270
 - e) 14 ... 350A (change step 1A) for ProMIG-350
 - f) 16 ... 500A (change step 1A) for ProMIG-500
 - g) 18 ... 630A (change step 1A) for ProMIG-630
- 11) [Fr.P] current pulsation frequency = 5.0 Hz (by default)
 - a) 0.2 ... 500 Hz (dynamic change step 0.1 Hz...1 Hz)
- 12) [dut] pulse/pause ratio (balance) - it is the percentage of the current pulse to the period of repetition of these pulses = 50% (by default)
 - a) 20 ... 80% (change step 5%)

TIG welding mode

- o) [-2-] main display parameter CURRENT = 100A (by default)
 - a) 8 ... 160A (change step 1A) for ProMIG-160
 - b) 10 ... 200A (change step 1A) for ProMIG-200
 - c) 12 ... 250A (change step 1A) for ProMIG-250
 - d) 12 ... 270A (change step 1A) for ProMIG-270
 - e) 14 ... 350A (change step 1A) for ProMIG-350
 - f) 16 ... 500A (change step 1A) for ProMIG-500
 - g) 18 ... 630A (change step 1A) for ProMIG-630
- 1) [But] torch button mode = [2T] (by default)
 - a) [LIFT] - contact striking mode TIG-LIFT
 - b) [2T] - non-contact striking mode, TIG-2T button mode. In case of connecting to an external oscillator for HF ignition.

c) [4T] - non-contact striking mode, TIG-4T button mode. In case of connecting to an external oscillator for HF ignition.

2) [Pr.A] pre-current (pilot arc) = 15A (by default). The parameter is used for 2T and 4T button modes.

- a) 8 ... 50A (change step 1A) for ProMIG-160
- b) 10 ... 50A (change step 1A) for ProMIG-200
- c) 12 ... 50A (change step 1A) for ProMIG-250
- d) 12 ... 50A (change step 1A) for ProMIG-270
- e) 14 ... 50A (change step 1A) for ProMIG-350
- f) 16 ... 50A (change step 1A) for ProMIG-500
- g) 18 ... 50A (change step 1A) for ProMIG-630

3) [Po.A] crater filling current = 15A (by default). The parameter is used for 2T and 4T button modes.

- a) 8 ... 50A (change step 1A) for ProMIG-160
- b) 10 ... 50A (change step 1A) for ProMIG-200
- c) 12 ... 50A (change step 1A) for ProMIG-250
- d) 12 ... 50A (change step 1A) for ProMIG-270
- e) 14 ... 50A (change step 1A) for ProMIG-350
- f) 16 ... 50A (change step 1A) for ProMIG-500
- g) 18 ... 50A (change step 1A) for ProMIG-630

4) [t.uP] current build-up time = 0.3 (by default)

- a) 0.1 ... 15.0 sec (change step 0.1 sec)

5) [t.dn] current ramp-down time = 0.3 (by default)

- a) 0.1 ... 15.0 sec (change step 0.1 sec)

6) [Po.P] current pulsation mode = OFF (by default)

- a) ON – enabled
- b) OFF – disabled

7) [I.iP] pulse current = 100A (by default)

- a) 8 ... 160A (change step 1A) for ProMIG-160
- b) 10 ... 200A (change step 1A) for ProMIG-200
- c) 12 ... 250A (change step 1A) for ProMIG-250
- d) 12 ... 270A (change step 1A) for ProMIG-270
- e) 14 ... 350A (change step 1A) for ProMIG-350
- f) 16 ... 500A (change step 1A) for ProMIG-500
- g) 18 ... 630A (change step 1A) for ProMIG-630

8) [I.PS] pause current = 100A (by default)

- a) 8 ... 160A (change step 1A) for ProMIG-160
- b) 10 ... 200A (change step 1A) for ProMIG-200
- c) 12 ... 250A (change step 1A) for ProMIG-250
- d) 12 ... 270A (change step 1A) for ProMIG-270
- e) 14 ... 350A (change step 1A) for ProMIG-350
- f) 16 ... 500A (change step 1A) for ProMIG-500
- g) 18 ... 630A (change step 1A) for ProMIG-630

- 9) [Fr.P] current pulsation frequency = 10.0 Hz (by default)
 - a) 0.2 ... 500 Hz (dynamic change step 0.1 Hz...1 Hz)
- 10) [dut] pulse/pause ratio (balance) – it is the percentage of the current pulse to the period of repetition of these pulses = 50% (by default)
 - a) 20 ... 80% (change step 5%)

MIG/MAG welding mode

Left indicator of the source:

- o) [-3-] main displayed parameter VOLTAGE = 19.0 V (by default)
 - a) 12 ... 24.0V (change step 0.1V) for ProMIG-160
 - b) 12 ... 26.0V (change step 0.1V) for ProMIG-200
 - c) 12 ... 28.0V (change step 0.1V) for ProMIG-250
 - d) 12 ... 29.0V (change step 0.1V) for ProMIG-270
 - e) 12 ... 32.0V (change step 0.1V) for ProMIG-350
 - f) 12 ... 40.0V (change step 0.1V) for ProMIG-500
 - g) 12 ... 44.0V (change step 0.1V) for ProMIG-630
- 1) [But] torch button mode = [2T] (by default)
 - a) [2T] - 2T torch button mode
 - b) [4T] - 4T torch standard button mode
 - c) [alt.4T] - 4T torch alternative button mode
- 2) [Ind] inductance = OFF (by default)
 - a) 0 [OFF] ... Stage 6 (change step 1 stage)
- 3) [t.Pr] shielding gas pre-purge time = 0.1 sec (by default)
 - a) 0.1 ... 25.0 sec (change step 0.1 sec)
- 4) [t.Po] shielding gas post-purge time = 1.5 sec (by default)
 - a) 0.1 ... 25.0 sec (change step 0.1 sec)
- 5) [t.up] voltage build-up time = OFF (by default)
 - a) 0 [OFF] ... 5.0 sec (change step 0.1 sec)
- 6) [t.dn] voltage ramp-down time = 0.1 sec (by default)
 - a) 0.1 ... 5.0 sec (change step 0.1 sec)

Right indicator of the wire feeder:

- o) [-1-] main displayed parameter FEED SPEED = 7.0 m/min (by default)
 - a) 2.0 ... 16.0 m/min (change step 0.1 m / min)
- 1) [But] torch button mode = [2T] (by default)
 - a) [2T] - 2T torch button mode
 - b) [4T] - 4T torch standard button mode
 - c) [alt.4T] - 4T torch alternative button mode
- 2) [Dru] wire feed motor ON/OFF = ON (by default)
 - a) ON - enabled (if there is a connection, the unit turns on automatically in the MIG/MAG mode)
 - b) OFF - disabled (if there is a connection, the unit turns off automatically in the MMA and TIG mode)

- 3) [t.Pr] shielding gas pre-purge time = 0.1 sec (by default)
 - a) 0.1 ... 25.0 sec (change step 0.1 sec)
- 4) [t.Po] shielding gas post-purge time = 1.5 sec (by default)
 - a) 0.1 ... 25.0 sec (change step 0.1 sec)
- 5) [t.uP] wire feed speed build-up time = 0.1 sec (by default)
 - a) 0 [OFF] ... 5.0 sec (change step 0.1 sec)
- 6) [t.dn] wire feed speed ramp-down time = OFF (by default)
 - a) 0 [OFF] ... 5.0 sec (change step 0.1 sec)

8. GENERATOR OPERATION

The power supply is suitable for generator operation, provided as follows:

When working with an electrode	Set current value for MMA and TIG	When working with wire diameter of MIG/MAG	Minimum generator power
Ø2	not more than 80A	not more than Ø 0.6 mm	3.0 kVA
Ø3	not more than 120A	not more than Ø 0.8 mm	4.5 kVA
Ø4	not more than 160A	not more than Ø 1.0 mm	6.0 kVA
Ø5	not more than 200A	not more than Ø 1.0 mm	7.7 kVA
Ø6 fusible	not more than 250A	not more than Ø 1.2 mm	10 kVA
Ø6 fusible	not more than 270A	not more than Ø 1.2 mm	12.0 kVA
Ø6	not more than 350A	not more than Ø 1.4 mm	16.0 kVA
Ø8 fusible	not more than 500A	not more than Ø 1.6 mm	30.5 kVA
Ø8	up to 630A	not more than Ø 2.0 mm	42.0 kVA

For trouble-free operation! The output line-to-line voltage of the generator must not exceed the permissible limits:

- 160-260V (for ProMIG-160/200/250);
- 320-440V for all three phases (for ProMIG-270/350/500/630).

9. CARE AND MAINTENANCE

Caution! Before opening the unit, be sure to turn it off, disconnect the mains plug. Allow the internal circuits of the unit to discharge (about 5 minutes), and only then proceed to other actions. When leaving, install a sign prohibiting to start the unit.

In order to keep the unit operational for many years, be sure to follow several rules:

- carry out a safety inspection at specified intervals (see Section "Safety instructions");
- with intensive use, we recommend that you blow the unit with dry compressed air every six months. Caution! Blowing from a short distance can result in damage to the electronic components;
- if there is a lot of dust, clean the cooling system ducts manually.

10. STORAGE

Store the conserved and packaged source under storage conditions 4 in accordance with GOST 15150-69 for a period of up to 5 years.

The de-conserved source should be stored in dry closed premises at an air temperature not lower than +5 °C. The premises should be free of acid vapours and other active substances.

11. TRANSPORTATION

The packed source is suitable to be transported by all transport means ensuring its safety in compliance with the transport rules established for the applicable type of transport.

12. SCOPE OF SUPPLY

- | | |
|---|---------|
| 1. Arc power source with mains cable | - 1 pc; |
| 2. Wire feeder | - 1 pc; |
| 3. PATON corrugated box | - 1 pc; |
| 4. Cable with electrode holder ABICOR BINZEL | - 1 pc; |
| 5. Welding cable with ground terminal ABICOR BINZEL | - 1 pc; |
| 6. Quick-release pneumatic connector | - 1 pc; |
| 7. User manual | - 1 pc; |

For ProMIG-160-15-2/200-15-2/250-15-2/270-15-2:

- | | |
|--|-----------|
| - Semi-automatic torch ABICOR BINZEL | - 1 pc; |
| - Rollers for solid wire (0.6-0.8; 1.0-1.2) | - 2 sets; |
| - Belt for attaching the source to the wire feeder | - 1 pc; |

For ProMIG-250-15-4/270-15-4/350-15-4:

- | | |
|--|-----------|
| - Semi-automatic torch ABICOR BINZEL | - 1 pc; |
| - Rollers for solid wire (0.8-1.0; 1.2-1.6) | - 2 sets; |
| - Rollers for aluminium wire (0.8-1.0) | - 1 set; |
| - Belt for attaching the source to the wire feeder | - 1 pc; |

For ProMIG-500-15-4/630-15-4:

- | | |
|---|-----------|
| - Rollers for solid wire (0.8-1.0; 1.2-1.6) | - 2 sets; |
| - Rollers for aluminium wire (0.8-1.0) | - 1 set. |

13. SAFETY RULES

GENERAL

The welding unit is manufactured in accordance with technical standards and established safety rules. However, if handled incorrectly, there is a hazard of:

- injury to service personnel or a third party;
- damage to the unit itself or to the company's material assets;
- disruptions to an effective workflow.

All persons involved in the commissioning, operation, care and maintenance of the unit must

- be appropriately certified;
- have expertise in welding;

- strictly follow these instructions.

The malfunctions that could impair safety must be urgently rectified.

USER RESPONSIBILITIES

The User undertakes to admit to work on the welding unit only the persons who:

- reviewed the basic safety rules, received training on the use of welding equipment;
- read the Section "Safety instructions" and the instructions on necessary precautions given in this manual, and confirm this with their signature.

PERSONAL PROTECTIVE EQUIPMENT

For personal protection, observe the following rules:

- wear protective footwear that retains insulating properties, even in wet conditions;
- protect hands with insulating gloves;
- protect eyes with a protective mask with an anti-UV filter that meets safety standards;
- use only suitable (highly inflammable) clothing.

HAZARD OF HARMFUL GASES AND VAPOURS

- remove generated smoke and harmful gases from the working area with special means;
- ensure sufficient supply of fresh air;
- vapours of solvents should not get into the radiation zone of the welding arc.

HAZARD OF SPARKLES

- remove flammable objects from the working area;
- do not perform welding works on containers where gases, fuel, oil products are or were stored. Potential explosion hazard for residues of these products;
- in fire and explosion hazardous areas, observe the special rules in accordance with national and international standards.

HAZARD OF MAINS AND WELDING CURRENT

- electric shock can be fatal;
- magnetic fields created by the high current can have a negative effect on the performance of electrical devices (e.g., a pacemaker). Persons with such devices should seek the advice of a physician before approaching a welding area;
- the welding cable must be robust, undamaged, and insulated. Loose connections and damaged cables must be replaced immediately. An electrician must systematically check the mains cables and cables of the welding unit for proper insulation;
- do not remove the outer casing of the unit during use.

INFORMAL PRECAUTIONS

- keep the instruction near the place of use of the welding unit at all times;
- in addition to the instructions, observe the applicable general and local safety and environmental regulations;
- keep all instructions on the welding unit legible.

STRAY WELDING CURRENTS

- make sure that the ground cable terminal is firmly connected to the unit;
- if possible, do not install the welding unit directly on an electrically conductive floor or work table, use insulating gaskets.

REGULAR USE PRECAUTIONS

Check the unit at least once a week for external damage and the operation of the safety units.

Wiring schematic diagram PATON ProMIG-160/200/250 DC MMA/TIG/MIG/MAG

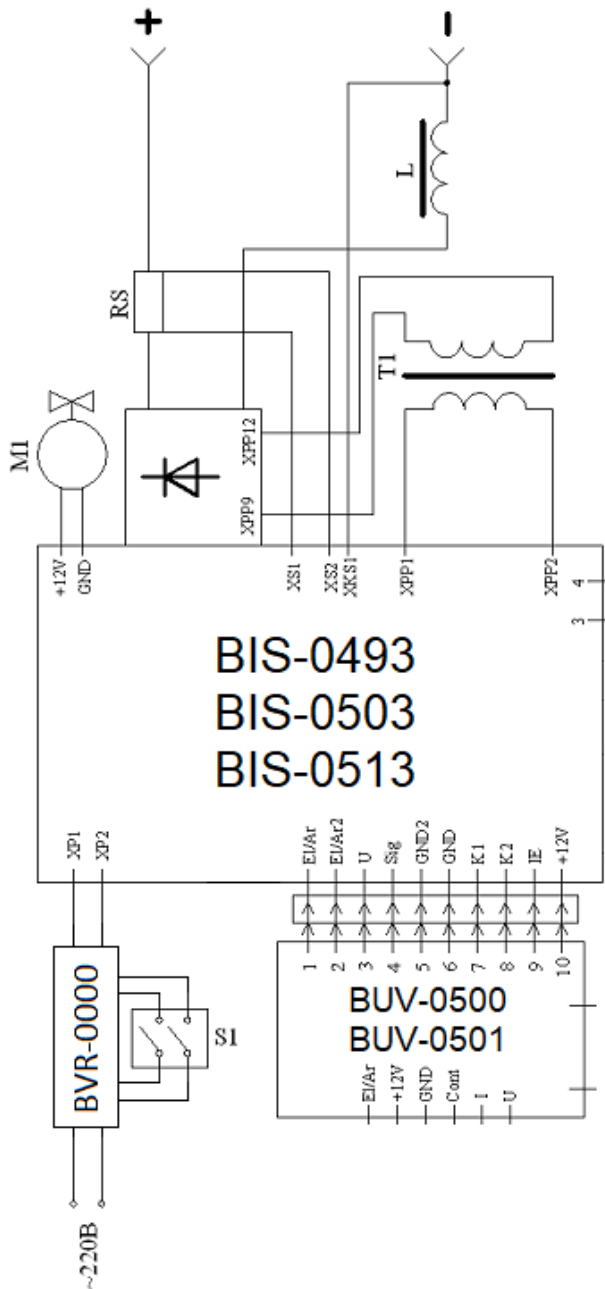

Wiring schematic diagram PATON ProMIG-270-400V/350-400V DC MMA/TIG/MIG/MAG

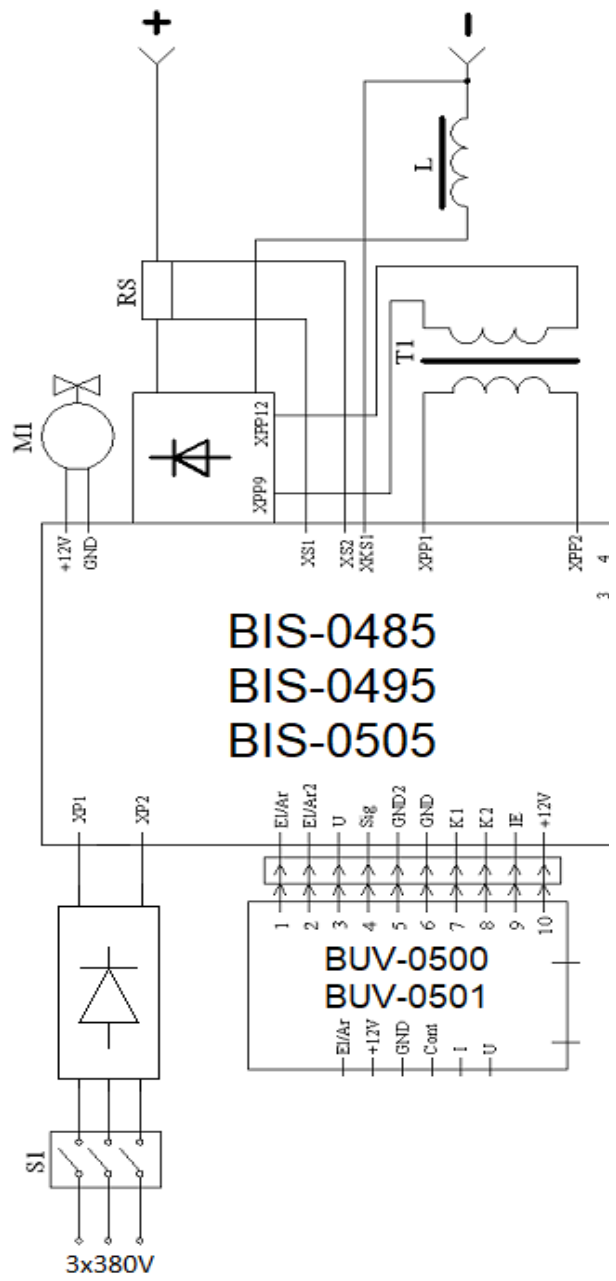

Wiring schematic diagram of the internal unit PATON Pro MIG-500400V/630-400V DC MMA/TIG/MIG/MAG

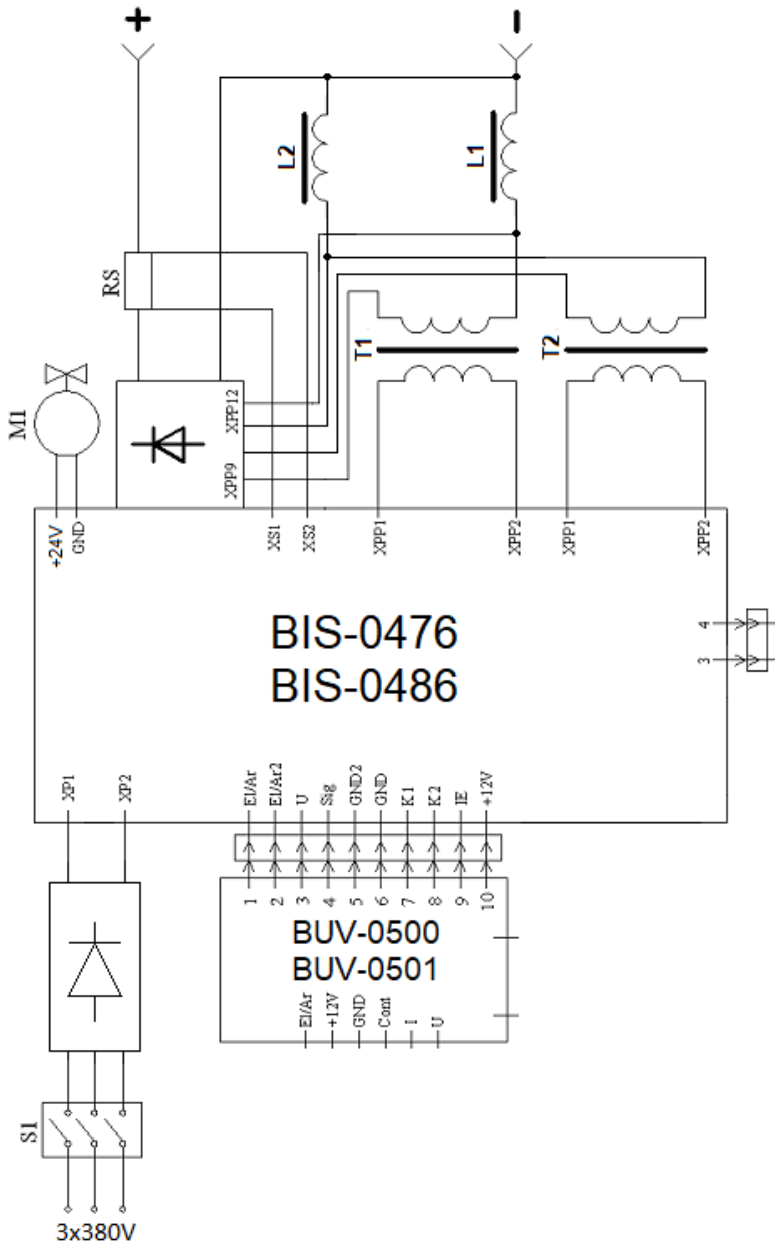

14. WARRANTY OBLIGATIONS

PATON INTERNATIONAL guarantees the correct operation of the power supply provided that the consumer observes the rules of operation, storage and transportation.

CAUTION! There is no free warranty service for mechanical damage to the welding unit!

Unit model	Warranty period
ProMIG-200	5 years
ProMIG-250	
ProMIG-270-400V	3 years
ProMIG-350-400V	
ProMIG-500-400V	2 years
ProMIG-630-400V	

The main warranty period starts from the date the inverter equipment is sold to the end customer.

During the main warranty period, the seller undertakes, free of charge for the owner of PATON inverter equipment:

- to make diagnostics and identify the cause of the malfunction;
- to provide assemblies and elements necessary for the repair;
- to carry out work to replace the failed elements and assemblies;
- to test the repaired equipment.

The main warranty obligations do not apply to the equipment:

- with mechanical damage that affected the performance of the unit (deformation of the housing and parts as a result of falling from a height or falling of heavy objects on the equipment, falling out of buttons and connectors);
- with traces of corrosion, which caused a malfunction;
- failed due to exposure of abundant moisture to its power and electronic elements;
- failed due to the accumulation of conductive dust inside (coal dust, metal shavings, etc.),
- in case of an attempt to independently repair its components and/or replace electronic elements;
- it is recommended to clean the internal elements and assemblies of this equipment, with compressed air, to remove the protective cover, depending on the operating conditions, once every six months, in order to avoid the breakdown of the unit. Cleaning should be done carefully, keeping the compressor hose at a sufficient distance to avoid damage to the soldering of the electronic components and mechanical parts.

Also, the main warranty obligations do not apply to failed external elements of the equipment exposed to physical contact, and related/consumable materials; the claims to the following are accepted no later than two weeks after the sale:

- on and off button;
- knobs for adjusting welding parameters;
- connectors for connecting cables and hoses;

- control connectors;
- mains cable and mains cable plug;
- carrying handle, shoulder strap, case, box;
- electrode holder, ground terminal, torch, welding cables and hoses.

The seller reserves the right to refuse to provide warranty repairs, or to set the month and year of manufacture of the unit as the start date for the fulfilment of warranty obligations (established by the serial number):

- if the owner loses the data sheet,
- in the absence of correct or even any kind of entries in the data sheet by the seller when selling the unit;
- the warranty period is extended for the period of warranty service of the unit in the service centre.